

M-iClean UM – Undercounter dishwasher

All MEIKO dishwashing machines are designed and built to provide maximum efficiency. That's what customers expect – and that's exactly what they get. But the M-iClean goes even further. Equipped with the full spectrum of innovative warewashing technology, the M-iClean's intuitive operating concept ensures maximum efficiency and reliability.

Execution for: United Arab Emirates Dishwashing machine

Fresh water line: Soft cold water 0-3 °dH
 3-phase current: 3N PE 400V 50Hz
 GiO MODULE (separate)
 Thermolabel



GiO Module (separately)
 Dimensions: 600 x 700 x 600 mm

Technical data

Rack capacity/h (theoretical)	40 / 30 / 20 racks/h
Programme cycle	90 / 120 / 180 s
Rack dimension	500 x 500 mm
Entry height	315 mm
Dimensions (W x Hmin x D)	600 x 700 x 600 mm
Electrical feeding cable	3-phase current 3N PE 400V 50Hz* Total connected load: 11.4 kW max. rated current: 19.6 A
Local fuse protection	25 A
Machine protection class	IP X5
Equipment	Control system MIKE CPU4 Bluetooth interface for wireless communication Leakage detector Boiler safety device Automatic self-cleaning when tank is drained Thermolabel Integrated reverse osmosis (with connection and discharge set)
Fresh water line	For reverse osmosis: connecting set with stop valve, Pressure regulator, filter 10 µm with activated carbon Internal: air gap 'AB' in accordance with EN 1717 with booster pump
Fresh water supply	Minimum flow pressure 100 kPa / 1.0 bar in front of solenoid valve Maximum pressure 500 kPa / 5.0 bar in front of pressure reducer Max. supply water temperature 35 °C
Flow rate	total 4.3 l/min (at 15 °C inlet temperature and a flow pressure of 200 kPa / 2 bar) Permeate 2.0 l/min Concentrate 2.3 l/min

Fresh water thresholds	Temperature cold water min. 1 °C to max. 35 °C electrical conductivity < 1000 µS/cm Total hardness max. 28 dH / 5 mmol/l CaCO ₃ Free of particles > 10 µm Iron < 0.10 mg/l Manganese < 0.04 mg/l Chlorine < 0.10 mg/l (free chlorine) Potassium permanganate < 10 mg/l Silicic acid < 10 mg/l
Final rinse water quantity	2.4 liters/cycle, variable
Boiler	Contents: 7.9 l Heater: 6.00 kW Temperature: 83 °C
Wash tank	Filling: 11.0 l Heater: 4.50 kW Temperature: 74 °C
Wash pump, with frequency converter	Performance: 0.50 kW
Dosing of rinse aid	Hose pump (24 V) with time control and suction lance
Detergent dosage	Hose pump (24 V) with time control and suction lance
Material	Cladding: 1.4301 Wash tank: 1.4301 Boiler: 1.4571
Heat emission	for 10 programme cycles/h total: 1.1 kW perceptible: 0.7 kW latent: 0.4 kW
Ventilation flow rate	270 m ³ /h
Steam emission	0.5 kg/h
Emission sound pressure level at the workplace (L_{pA})	60 dB
Net / gross weight	86.8 kg / 98.6 kg (standard packaging)
Packaging dimensions (W x H x D)	700 x 1050 x 700 mm (standard packaging)

*Note:
Electrical equipment suitable for supply voltage:
3N PE 400 V 50 HZ (3N PE 380-415 V 50 Hz)
1N PE 230 V 50 HZ (1N PE 220-240 V 50 Hz)

1.0	machine connection: drain connection hose, DN 22 hose fitted as odour trap in interior of machine
1.1	drain (max. 300 mm above finished floor level), DN 50
2.0	Machine connection: fresh water supply, G 3/4"
2.2	Soft cold water 10°C, DN 15, G 3/4 a max. 0,54 mmol/l CaCO ₂ (max. 3°dH) electrical conductivity < 1000 µS/cm Minimum flow pressure: 100 kPa / 1.0 bar in front of solenoid valve Maximum pressure: 500 kPa / 5.0 bar in front of pressure reducer stopcock and fine screen ≤ 25 µm
3.0	Machine connection: electrical connection cable 5G 4mm ²
3.1	electricity supply to the machine: 3N PE 400V ~ 50Hz nominal current / - capacity: 19.6 A / 11.4 kW Fuse protection: 25 A ⚡ Voltage equalising cable The master switch must be provided on site Note: Electrical equipment suitable for supply voltage: 3N PE 380-415 V 50 Hz / 1N PE 220-240 V 50 Hz
6.0	Heat load of warewash area
6.1	for 10 programme cycles/h total 1.1 kW, perceptible 0.7 kW, latent 0.4 kW
all cables, pipes etc leaving machine 1,6 m	
the position of the connection piping can also be mirror-inverted!	
Machine Equipment	
(A) Entry height	
Final rinse dosing unit with suction lance (blue connector)	
Detergent dosing unit and suction lance	
GiO MODULE (separate)	
Thermolabel	
	Please observe the installation indications of the additional document MP_T-INFO-GiO_EN.pdf

GiO MODULE (W x D x H) 140 x 550 x 600 mm
Connecting pipe from the module to the machine, 3 m long

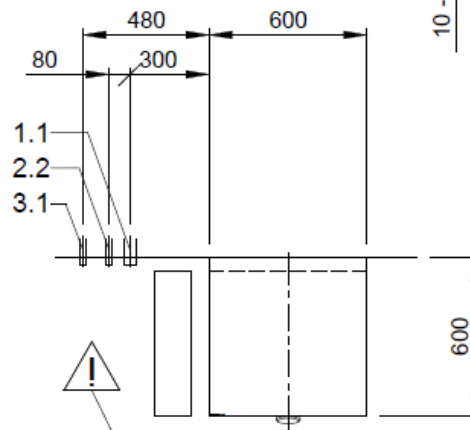
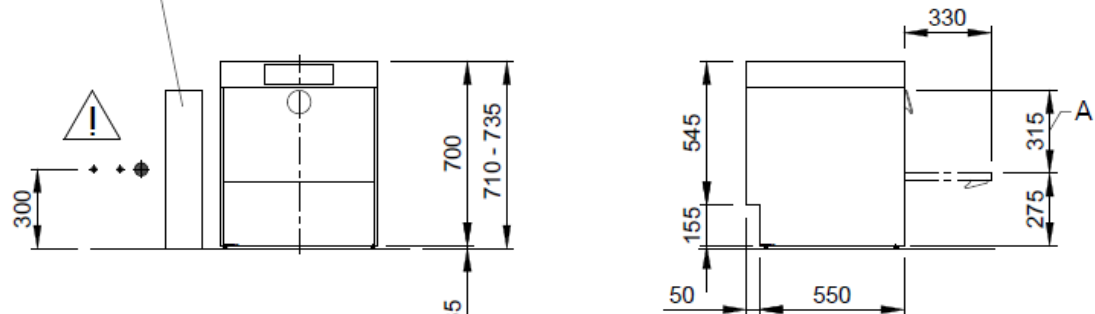

Please note:
Additional installation components are necessary (connection and drain kits)

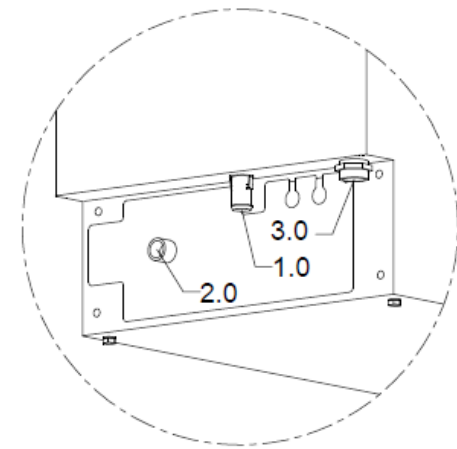

<p>MEIKO MIDDLE EAST FZE GoldDiamond Park, Building#6, office #206 P.O. Box 282365, U.A.E.-Dubai Phone +971 43 41 51 72 E-MAIL: wat@meiko.de</p> <p>This drawing may not be neither passed to third parties for their information or copied or used for competitive purposes without our consent. All rights reserved. We reserve the right to make changes resulting from technical progress. This drawing was computer generated and is not subject to the checking and any release process; it is also not subject to change management. Please note: This document is only valid in conjunction with the conditions defined in Supplementary Sheet "Important Information". These can be requested from the manufacturer or downloaded from the Partnet.</p>	Revision		
	Reference	DISHWASHER STANDARD DRAWING / ARE	
	Type	M-ICLEAN UM GiO MODULE SEPARATE THERMOLABEL	
	TYPE: CROCKERY		
Drawing-No.	S00079103		Order-No.
Scale	1:25	drawn:	15.04.2020 m-iplan
checked:		15.04.2020	m-iplan

MP000404621.2.2

©COPYRIGHT by MEIKO

ARE

EN

©COPYRIGHT by MEIKO