

UPster B Flight Type Dishwasher

UPster B 230VAP CSS-Top: Pre-wash + Wash + pump rinse + drying section

Capacity: 3000 / 3600 / 4100 plates/h

Heating: Electric

Working direction: Left to right

Power supply: 3N PE 380V 50Hz

Tank filling: Soft warm water



UPster B is the new generation of warewashing technology.

Perfectly tailored for people and the environment, economical, resource-efficient and user-friendly.

- MEIKO UPster B offers state-of-the-art technology at an impressively low price and offers an outstanding array of advanced technologies.
- Designed to make hygiene management more efficient than ever, it guarantees maximum cleanliness all the way down the line.
- The built-in chemical saving system CSS optimizes wash performance, reducing chemical use by up to 50 percent.
- The CSS-Top version goes even further, achieving reductions in chemical use of up to 80 percent.
- The intelligent AWS system significantly reduces the amount of water used by the warewasher, keeping the use of this valuable resource to a minimum while still maintaining sparkling clean results.

MEIKO UPster B. All the latest warewashing improvements in a single system.

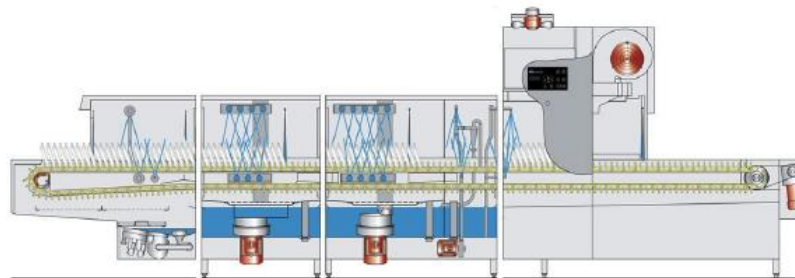

Schematic sectional view of machine

Technical data

Performance

- | | |
|-------------------------------|-----------------------------|
| ▪ Contact length | 2700 mm |
| ▪ Contact time | 2 minutes |
| ▪ Transport speed 1/2/3 (DIN) | 1.35 / 1.60 / 1.85 m/ min. |
| ▪ Dish Capacity (DIN) | 3000 / 3600 / 4100 plates/h |

Machine conveyor belt

- for dishes
- MTB 1.11 Multi-purpose conveyor

Motors

- Total 5.9 kW

Heating energies

- Total 33.1 kW

Electrical feeding cable

- Power supply 3N PE 380V 50Hz
- Total connected load 39 kW
- max. rated current 65.4 A
- Max. Elect. cable cross-section 35 mm²

Fresh water

- Fresh water final rinse: soft cold water 260 l/h

Tank filling

- Soft warm water 310 l

Air outlet

- Exhaust air volume approx. 800 m³/h
- Exhaust air temperature approx. 35 °C
- Relative humidity approx. 85 %

Heat load

- total 5.3 kW
- Perceptible 1.8 kW
- latent 3.5 kW

Dimensions of machine

- Feeding section 1400 mm
- Pre-wash tank 900 mm
- Wash tank 1300 mm
- Unloading section / drying section 2300 mm

Total 5900 mm

Machine separation

Separation at the unloading section

Equipment

Exhaust air heat recovery
 Heaters Incoloy 825
 Drying (TR 1100)

OPTION: Thermolabel test 71°C

Please note the kW load will increase to approx. 15kW if Thermolabel test is added.

Type code: B230VAP-nT-L-E1400-380/50-E-A2300-D1100-nC-IC	
1.1	Machine drain DN 70, dia. 75 a, Onsite pipe system connection and siphon
2.1	Water connection of the machine: Soft warm water 50°C, DN 20, G 3/4 a max. 0,54 mmol/l CaCO ₃ (max. 3°dH) consumption approx. 310 l for tank filling
2.2	Water connection of the machine: Soft cold water, DN 20, G 3/4 a max. 0,54 mmol/l CaCO ₃ (max. 3°dH) consumption approx. 260 l/h for final rinse
3.1	Electrical connection of the machine: 3N PE 380V 50Hz nominal current / - capacity: 65,4 A / 39,0 kW Max. Elect. cable cross-section: 35 mm ² free cable end from finished floor level/Wall: approx. 4 m ⚡ Voltage equalising cable
6.0	Heat load of warewash area The values apply for the following room conditions: Room temperature 22 °C, rel. humidity 55 % The total heat load includes 6.1 and 6.2
6.1	Machine exhaust air pipe, dia. 360 mm Heat load of the machine in normal washing operation: Latent: 3.5 kW, perceptible: 1.8 kW, total: 5.3 kW At a freshwater supply temperature of approx. 12°C
6.2	The heat load of the wash ware must be considered separately. For the total space load, all other space loads must be considered. The space ventilation must be designed in accordance with EN 16282.
 Separation Machine Equipment Exhaust air heat recovery heaters Incoloy 825	

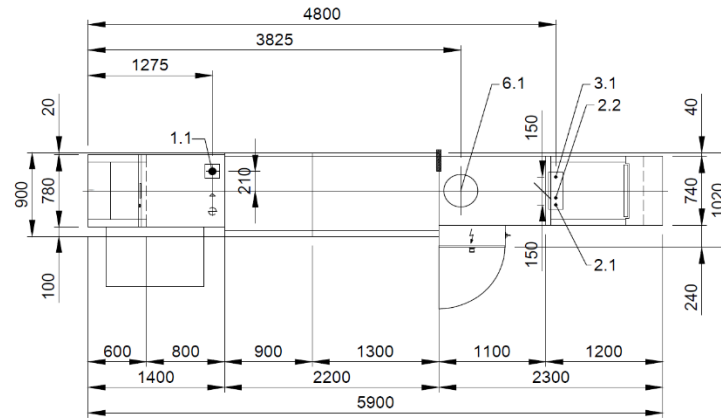
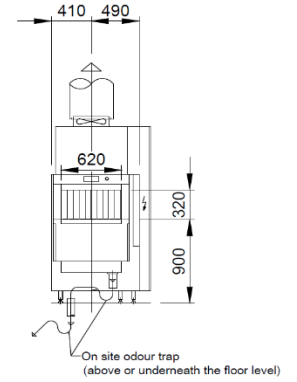
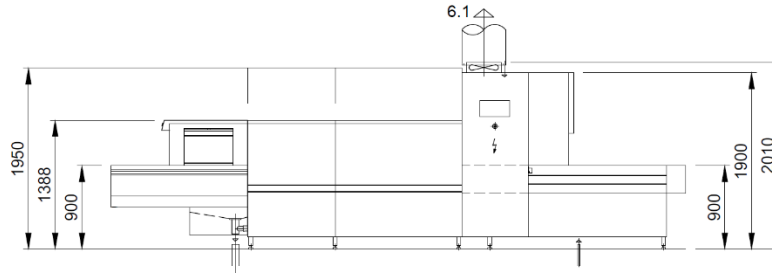

**RECOMMENDATION AIR OUTLET
EXTENSION ON SITE**
(exhaust air outlet or exhaust heat recovery)

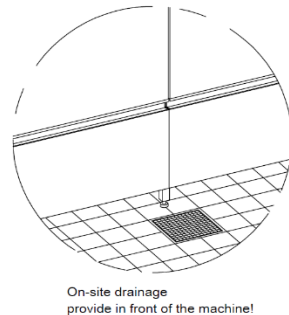
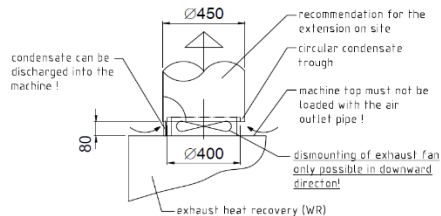

 MEIKO MIDDLE EAST FZE GoldDiamond Park, Building#6, office #206 P.O. Box 282365, U.A.E.-Dubai Phone +971 43 41 51 72 E-MAIL: wat@meiko.de	Revision	
	Reference	UPSTER STANDARD DRAWING / ABE
	Type	UPSTER B230VAP CSS-TOP L-R ELECTRO
	Drawing-No.	S00085581
This drawing may not be neither passed to third parties for their information or copied or used for competitive purposes without our consent. All rights reserved. We reserve the right to make changes resulting from technical progress. This drawing was computer generated and is not subject to the checking and any release process; It is also not subject to change management. Please note: This document is only valid in conjunction with the conditions defined in Supplementary Sheet "Important Information". These can be requested from the manufacturer or downloaded from the Partnernet.	Order-No.	
Scale	1:50	
drawn:	27.07.2020	m-i-plan
checked:	27.07.2020	m-i-plan
ARF	FN	