

UPster B Flight Type Dishwasher

UPster B 460VAP + Thermolabel: Pre-wash + wash + wash + Unloading section / drying section

Execution for: Saudi Arabia

Capacity: 3500 / 5300 / 6100 plates/h

Heating: Electric

Working direction: Left to right

Power supply: 3N PE 380V 60Hz

Tank filling: Soft warm water



UPster B is the new generation of warewashing technology.

Perfectly tailored for people and the environment, economical, resource-efficient and user-friendly.

- MEIKO UPster B offers state-of-the-art technology at an impressively low price and offers an outstanding array of advanced technologies.
- Designed to make hygiene management more efficient than ever, it guarantees maximum cleanliness all the way down the line.
- The built-in chemical saving system CSS optimizes wash performance, reducing chemical use by up to 50 percent.
- The CSS-Top version goes even further, achieving reductions in chemical use of up to 80 percent.
- The intelligent AWS system significantly reduces the amount of water used by the warewasher, keeping the use of this valuable resource to a minimum while still maintaining sparkling clean results.

MEIKO UPster B. All the latest warewashing improvements in a single system.

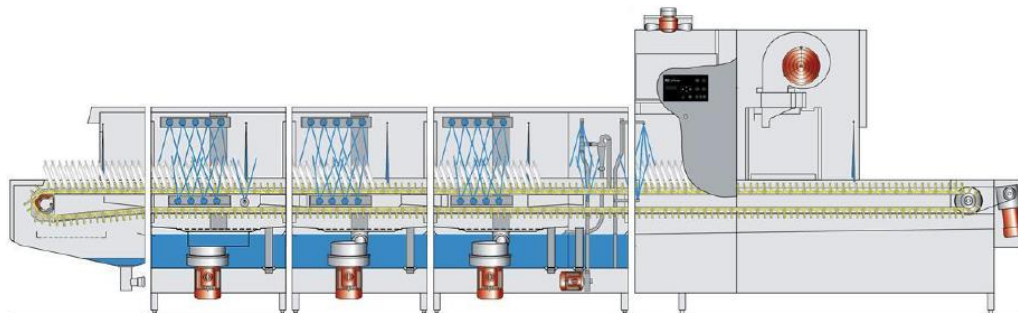

Schematic sectional view of machine

Technical data

Performance

- | | |
|-----------------------------|--------------------------|
| ▪ Contact length | 3100 mm |
| ▪ Contact time | 2 minutes |
| ▪ Transport speed 1 / 2 / 3 | 1.55 / 2.40 / 2.75 m/min |

Dish Capacity 3500 / 5300 / 6100 plates/h

Machine conveyor belt for dishes	MTB 1.11 Multi-purpose conveyor
Motors	
• Total	8.6 kW
Heating energies	
• Total	63.8 kW
Electrical feeding cable	
• Power supply	3N PE 380V 60Hz
• Total connected load	72.4 kW
• max. rated current	115.7 A
• Max. Elect. cable cross-section	95 mm ²
Fresh water	
• Fresh water final rinse: soft cold water	300 l/h
Tank filling	
• Soft warm water	410 l
Air outlet	
• Exhaust air volume approx.	800 m ³ /h
• Exhaust air temperature approx.	35 °C
• Relative humidity approx.	85 %
Heat load	
• total	5.6 kW
• Perceptible	2.1 kW
• latent	3.5 kW
Dimensions of machine	
• Feeding section	900 mm
• Pre-wash tank	900 mm
• Wash tank	900 mm
• Wash tank	1300 mm
• Unloading section / drying section	2600 mm
Total	6600 mm
Machine separation	Separation at the unloading section Separation between 1st and 2 nd Wash zone
Equipment	Exhaust air heat recovery Thermolabel Heaters Incoloy 825 Drying (TR1500)

Type code: B460VAP-T-L-E900-380/60-E-A2600-D1500-nC-IC	
1.1	Machine drain DN 70, dia. 75 a, Onsite pipe system connection and siphon
2.1	Water connection of the machine: Soft warm water 50°C, DN 20, G 3/4 a max. 0,54 mmol/l CaCO ₃ (max. 3°dH) consumption approx. 410 l for tank filling
2.2	Water connection of the machine: Soft cold water, DN 20, G 3/4 a max. 0,54 mmol/l CaCO ₃ (max. 3°dH) consumption approx. 300 lh for final rinse
3.1	Electrical connection of the machine: 3N PE 380V 60Hz nominal current / - capacity: 115.7 A / 72.4 kW Max. Elect. cable cross-section: 95 mm ² free cable end from finished floor level/Wall: approx. 4 m ⚡ Voltage equalising cable
6.0	Heat load of warewash area The values apply for the following room conditions: Room temperature 22 °C, rel. humidity 55 % The total heat load includes 6.1 and 6.2
6.1	Machine exhaust air pipe, dia. 360 mm Heat load of the machine in normal washing operation: Latent: 3.5 kW, perceptible: 2.1 kW, total: 5.6 kW At a freshwater supply temperature of approx. 12°C
6.2	The heat load of the wash ware must be considered separately. For the total space load, all other space loads must be considered. The space ventilation must be designed in accordance with EN 16282.
 Separation Machine Equipment Exhaust air heat recovery Thermlabel heaters Incoloy 825	

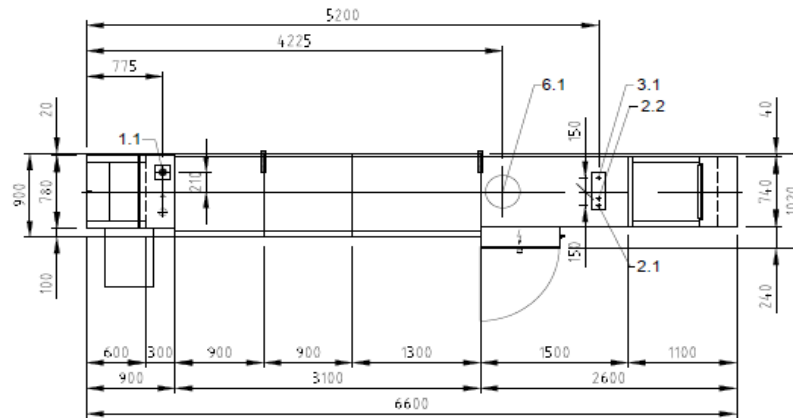
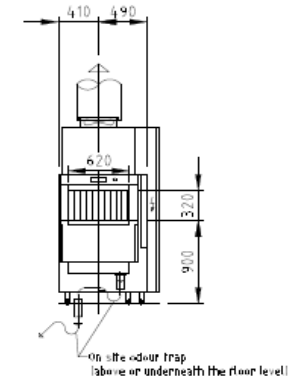
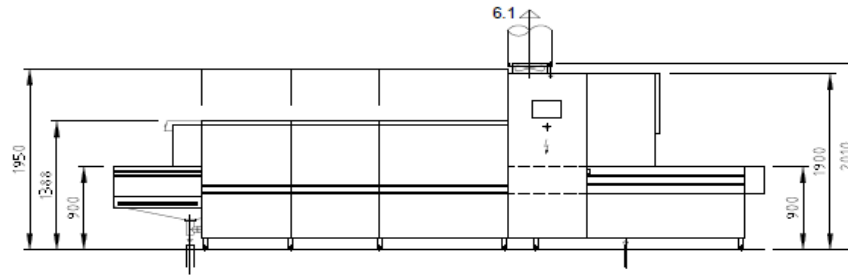

RECOMMENDATION AIR OUTLET EXTENSION ON SITE

(exhaust air outlet or exhaust heat recovery)

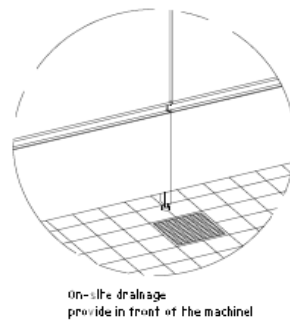
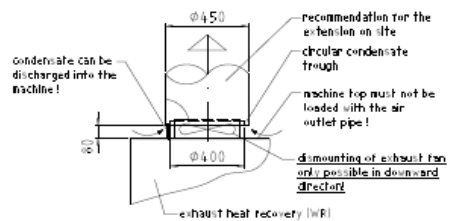

 MEMO MIDDLE EAST FZE GoldDiamond Park, Building#6, office #206 P.O. Box 282365, U.A.E.-Dubai Phone +971 42 41 51 72 E-MAIL: w@memo.ae	This drawing shall not be further passed to third parties for their reproduction or copied or used for competitive purposes without our consent. All rights reserved. We reserve the right to make changes resulting from technical progress. This drawing was computer generated and is not subject to the checking and any release process. It is subject to change without notice. This document is only valid in conjunction with the conditions, drawings and supplementary sheets. Important information - This can be requested from the manufacturer or downloaded from the Partnernet.		Reference UPSTER STANDARD DRAWING / SAU	Type UPSTER B460VAP L-R ELECTRO
	Drawing No. S00085623		Order No.	
	Scale 1:50	drawn 27.07.2020	checked 27.07.2020	
	SAU	EN	m-iplan	