

M-iClean HXL – Double Basket Hood type dishwasher

A new generation of appliances that are designed for outstanding ergonomics, improved warewashing performance, better quality indoor air, and sparkling results with every wash.

Key Features:

- Reliable hood mechanism
- New drying table
- Pipes made from stainless steel – robust and durable
- Flexible features at no extra cost:
 - Option to adjust height and mount on plinth
 - Easy to adjust / convert the electric power
 - Control panel can be mounted on either side of the machine.

Key Benefits:

- Makes dishwashing significantly quicker
- Dries washware much faster
- Gets tableware back in use sooner
- Reduces staff and running costs
- Improves staff absence rates
- Optimizes workplace assessments



Execution for: United Arab Emirates

Dishwashing machine

Fresh water line: Soft warm water 0-3°dH

3-phase current: 3N PE 400V 50Hz

Technical data

Rack capacity/h (theoretical)	120 / 80 / 34 racks/h
Programme cycle time	60 / 90 / 210 s
Rack dimension	2 x 500 x 500 mm (540 x 500 mm)
Entry height	505 mm
Dimensions (W x Hmin x D)	1180 (1270) x 1520 x 750 (800) mm (with handles)
Electrical feeding cable	3-phase current 3N PE 400V 50Hz* Total connected load: 20.1 kW max. rated current: 31.0 A
Local fuse protection	32 A
Protection class of the machine	IP X5
Equipment	Control system MIKE CPU4 Bluetooth interface for wireless communication Leakage detector Boiler safety device Automatic self-cleaning when tank is drained Drain pump Back wall cladding Automatic hood system Automatic basket detection
Fresh water line	Air gap 'AB' in accordance with EN 1717 with booster pump
Fresh water supply	Minimum flow pressure 60 kPa / 0.6 bar in front of solenoid valve Maximum pressure: 500 kPa / 5.0 bar

	Max. supply water temperature 60 °C
Flow rate	5 l/min
Final rinse water quantity	4.8 liters/cycle, variable
Boiler	Contents: 18.0 l Heater: 18.00 kW Temperature: 83 °C Tank / boiler locked
Wash tank	Filling: 54.0 l Heater: 8.00 kW Temperature: 60 °C
Wash pump	Performance: 2 x 0.75 kW
Dosing of rinse aid	Hose pump (24 V) with time control and suction lance
Detergent dosage	Hose pump (24 V) with time control and suction lance
Material	Cladding: 1.4301 Wash tank: 1.4301 Boiler: 1.4571
Heat emission	for 25 programme cycles/h total: 5.4 kW perceptible: 3.6 kW latent: 1.8 Kw
Ventilation flow rate	1360 m ³ /h
Steam emission	2.6 kg/h
Emission sound pressure level at the workplace (LpA)	67 dB
Net / gross weight	210.0 kg / 245.0 kg (standard packaging)
Packaging dimensions (W x H x D)	1000 x 1750 x 1350 mm (standard packaging)

*Note:
Electrical equipment suitable for supply voltage:
3N PE 400 V 50 HZ (3N PE 380-415 V 50 Hz)

1.0	machine connection: drain connection hose, DN 22 hose fitted as odour trap in interior of machine
1.1	drain (max. 700 mm above finished floor level), DN 50
2.0	Machine connection: fresh water supply, G 3/4"
2.1	Soft warm water 45-60°, DN 15, G 3/4 a max. 0,54 mmol/l CaCO ₃ (max. 3°dH) Flow rate: 5 l/min Minimum flow pressure: 60 kPa / 0,6 bar in front of solenoid valve Maximum pressure: 500 kPa / 5,0 bar stopcock and fine screen ≤ 25 µm
3.0	Machine connection: electrical connection cable 5G 10mm*
3.1	electricity supply to the machine: 3N PE 400V ~ 50Hz nominal current / - capacity: 31.0 A / 20.1 kW Fuse protection: 32 A ⚡ Voltage equalising cable The master switch must be provided on site Note: Electrical equipment suitable for supply voltage: 3N PE 380-415 V 50 Hz / 1N PE 220-240 V 50 Hz
6.0	Heat load of warewash area The values apply for the following room conditions: Room temperature 22 °C, rel. humidity 55 % ☒ Recommended suction area according to German EN 16282 or any local regulations have to be observed to determine ventilation of wash areas The total heat load includes 6.1
6.1	Heat load of the machine in normal washing operation: for 25 programme cycles/h total 5.4 kW, perceptible 3.6 kW, latent 1.8 kW For the total space load, all other space loads must be considered. The space ventilation must be designed in accordance with EN 16282.

all cables, pipes etc leaving machine 1,0 m
the position of the connection piping can also be mirror-inverted!
Height adjustable: machine feet +/- 30 mm, MEIKO table feet +/- 15 mm

Machine Equipment	
(A)	Entry height
(D)	Rinse agent pipe and suction lance
(E)	Detergent dosing unit with suction lance
	Automatic hood system
	Automatic basket detection
	Feeding table on site
	Discharge table on site

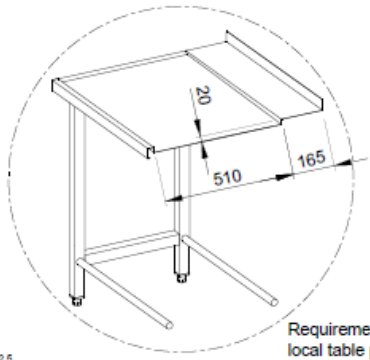
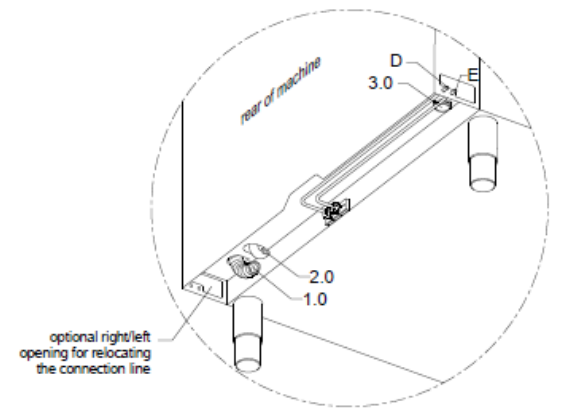
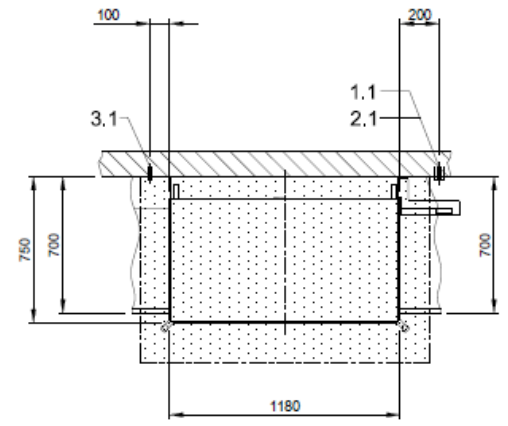
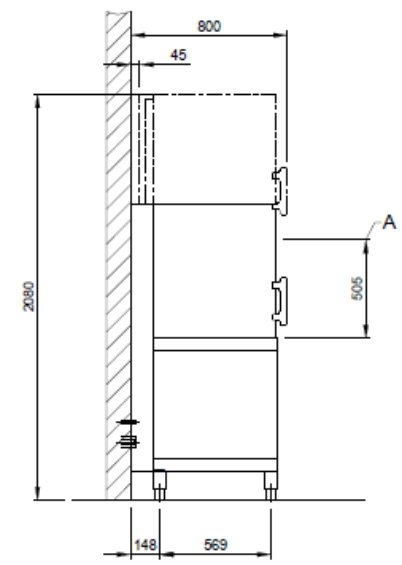
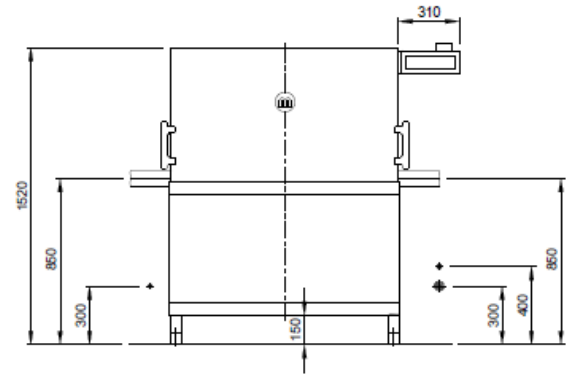

MP000431578 2.5

<p>MEIKO MIDDLE EAST FZE GoldDiamond Park, Building#6, office #206 P.O. Box 282385, U.A.E -Dubai Phone +971 43 41 51 72 E-MAIL: wat@meiko.de</p> <p><small>This drawing may not be neither passed to third parties for their information or copied or used for competitive purposes without our consent. All rights reserved. We reserve the right to make changes resulting from technical progress. This drawing was computer generated and is not subject to the checking and any release process; it is also not subject to change management. Please note: This document is only valid in conjunction with the conditions defined in Supplementary Sheet "Important Information". These can be requested from the manufacturer or downloaded from the Partnernet.</small></p>	Revision	Reference	Type
		DISHWASHER STANDARD DRAWING / ARE	M-ICLEAN HXL M2
	TYPE: CROCKERY	Drawing-No.	Order-No.
	S00087923	Scale	checked
	1:25	09.08.2020 m-iplan	09.08.2020 m-iplan