

UPster U 500G M2 Gio

Undercounter glass washer

MEIKO's new UPster® U M2 range of undercounter dishwashers pulls out all the stops when it comes to professional warewashing technology, offering efficient cleaning performance, easy operation, maximum flexibility, and exceptional value for money. The perfect choice for your wash-up area. Simply plug it in and you're ready to go!



Execution for: Saudi Arabia

Glasswasher

Fresh water line: Soft cold water 0-3 °dH

3-phase current: 3N PE 400V 60Hz

Gio Module

Technical data

Rack capacity/h (theoretical)

40 / 30 / 15 racks/h

Programme cycle

90 / 120 / 240 s

Rack dimension

500 x 500 mm (540 x 500)

Entry height

315 mm

Dimensions (W x Hmin x D)

600 x 700 x 600 mm

Electrical feeding cable

3-phase current 3N PE 400V 60Hz*

Total connected load: 8.4 kW

max. rated current: 18.4 A

Local fuse protection

20 A

Machine protection class

IP X4

Equipment

Control system MIKE CPU1

Infrared interface for wireless communication

Leakage detector

Soft start

Boiler safety device

Drain pump

AktivPlus wash water filter system

Automatic self-cleaning when tank is drained

Gio Module

Fresh water line

For reverse osmosis: connecting set with stop valve,

Pressure regulator, filter 10 µm with activated carbon

Internal: air gap 'AA' in accordance with EN 1717 with booster pump

Fresh water supply

Minimum flow pressure 100 kPa / 1.0 bar in front of solenoid valve

Maximum pressure 500 kPa / 5.0 bar in front of pressure reducer

Max. supply water temperature 35 °C

Flow rate	total 5.5 l/min (at 15 °C inlet temperature and a flow pressure of 200 kPa / 2 bar) Permeate 2.0 l/min Concentrate 3.5 l/min
Fresh water thresholds	Temperature cold water min. 1 °C to max. 35 °C electrical conductivity < 1000 µS/cm Total hardness max. 28 dH / 5 mmol/l CaCO ₃ Free of particles > 10 µm Iron < 0.10 mg/l Manganese < 0.04 mg/l Chlorine > 0.10 mg/l (free chlorine) Potassium permanganate < 10 mg/l Silicic acid < 10 mg/l
Final rinse water quantity	2.6 liters/cycle
Boiler	Contents: 7.0 l Heater: 7.50 kW Temperature: 65 °C Tank / boiler locked
Wash tank	Filling: 11.0 l Heater: 2.00 kW Temperature: 60 °C
Wash pump	Performance: 0.55 kW
Dosing of rinse aid	Hose pump (24 V) with time control and suction lance
Detergent dosage	Hose pump (24 V) with time control and suction lance
Material	Cladding: 1.4301 Wash tank: 1.4301 Boiler: 1.4404
Heat emission	for 20 programme cycles/h total: 2.1 kW perceptible: 1.4 kW latent: 0.7 kW
Ventilation flow rate	540 m ³ /h
Steam emission	1.0 kg/h
Emission sound pressure level at the workplace (LpA)	63 dB

1.0	machine connection: drain connection hose, DN 22 hose fitted as odour trap in interior of machine
1.1	drain (max. 700 mm above finished floor level), DN 50
2.0	Machine connection: fresh water supply, G 3/4"
2.2	Soft cold water 10°C, DN 15, G 3/4 a max. 0,54 mmol/l CaCO ₂ (max. 3°dH) Flow rate: total 5.5 l/min (at 15 °C inlet temperature and a flow pressure of 200 kPa / 2 bar) electrical conductivity < 1000 µS/cm Minimum flow pressure: 100 kPa / 1.0 bar in front of solenoid valve Maximum pressure: 500 kPa / 5.0 bar in front of pressure reducer stopcock and fine screen ≤ 25 µm
3.0	Machine connection: electrical connection cable 5G 2,5mm ²
3.1	electricity supply to the machine: 3N PE 400V ~ 60Hz nominal current / - capacity: 18.4 A / 8.4 kW Fuse protection: 20 A ⊕ Voltage equalising cable The master switch must be provided on site Electrical equipment suitable for supply voltage: 3N PE 380-415 V 60 Hz
6.0	Heat load of warewash area
6.1	for 20 programme cycles/h total 2.1 kW, perceptible 1.4 kW, latent 0.7 kW
all cables, pipes etc leaving machine 1,6 m	
the position of the connection piping can also be mirror-inverted!	
Machine Equipment	
(A) Entry height	
(D) Rinse agent pipe and suction lance	
(E) Detergent dosing unit with suction lance	
Chlorine-resistant membrane (> 0,1 mg/l bis 2,0 mg/l)	
	Please observe the installation indications of the additional document MP_T-INFO-GIO_EN.pdf

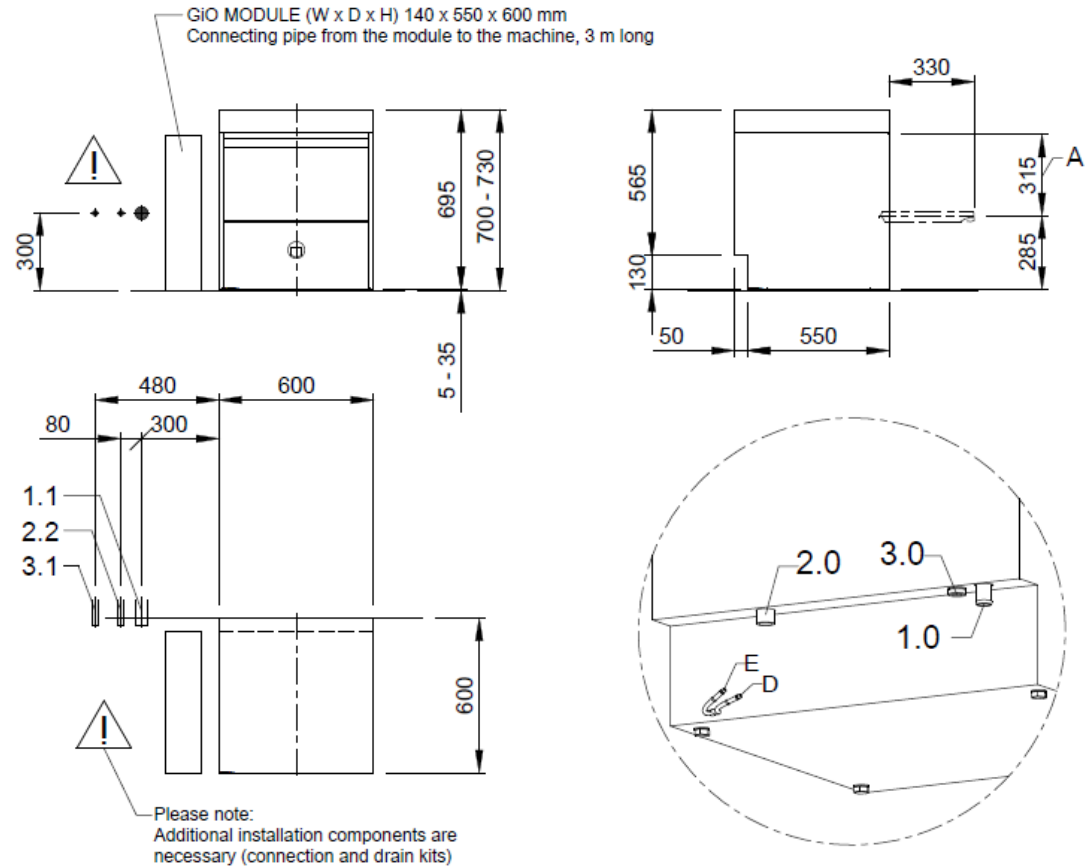

MP000403590.1.7
©COPYRIGHT by MEIKO

<p>MEIKO MIDDLE EAST FZE GoldDiamond Park, Building#6, office #206 P.O. Box 282365, U.A.E.-Dubai Phone +971 43 41 51 72 E-MAIL: wat@meiko.de</p>	Revision		
	Reference	DISHWASHER STANDARD DRAWING / SAU	
<p>This drawing may not be neither passed to third parties for their information or copied or used for competitive purposes without our consent. All rights reserved. We reserve the right to make changes resulting from technical progress. This drawing was computer generated and is not subject to the checking and any release process; it is also not subject to change management. Please note: This document is only valid in conjunction with the conditions defined in Supplementary Sheet "Important Information". These can be requested from the manufacturer or downloaded from the Partnernet.</p>	Type	UPSTER U 500G M2 GIO MODULE SEPARATE	
	Drawing-No.	S00078831	
Scale	1:25	Order-No.	
drawn:	08.04.2020 m-iplan	checked:	08.04.2020 m-iplan

SAU EN

©COPYRIGHT by MEIKO